

NOTICE

Read this entire manual to understand how the EVC functions before beginning the installation process. Do not attempt to install or adjust the EVC without thorough knowledge of how this unit works. This manual assumes that you have the knowledge in the operation of tools and equipment that are necessary to safely perform service operations on your vehicle. This manual also assumes that you are familiar with typical automotive systems and basic service and repair procedures. Always have access to a factory repair manual as some of the procedures and specifications required for the proper installation of this product may be referenced to the factory repair manual. To avoid the risk of personal injury, follow the lifting, supporting, and safety precautions contained in the factory repair manual.

USER NOTES

- The EVC can be used on both internal and external wastegate type turbochargers.
- The EVC is not capable of reaching boost levels lower than stock (OEM) levels.
- The EVC will maintain its programming even if the vehicle's battery is disconnected or the head unit is unplugged.
- The serial numbers must match on the control unit and the stepping motor in order for the unit to function properly.
- The EVC is a sensitive electronic component and must be handled with extreme care. Miswiring or shock will damage the unit. Do not place near extreme heat, water, or areas prone to dirt and dust.
- Most factory turbocharged vehicles come equipped with a secondary boost limiting system (fuel-cut system or pop-off valve) to protect against wastegate failure. Due to this, the EVC alone will not be able to raise the boost pressure beyond the point of the factory limit. If this condition occurs, consult your HKS distributor for information regarding products that can assist in this situation (HKS Fuel Cut Defencer, HKS Vein Pressure Converter, HKS Programmed Fuel Computer, etc.).
- If the vehicle has a fuel cut defense system such as the HKS FCD, make certain that the vehicle's boost pressure is not raised excessively, as this will lead to engine and/or turbocharger damage. HKS will not warranty any damage caused by excessive boost levels.
- Make sure the vehicle has a proper fuel management system that can handle higher boost pressures than stock (OEM) levels. HKS will not warranty damage caused by improper fuel management (lean air/fuel ratio).
- The EVC cannot control boost pressure above the maximum efficiency point of the turbocharger. Boost pressure drop at high rpm may not be totally eliminated. The EVC will not be able to compensate for pressure loss due to turbocharger sizing. Boost creep or boost spikes due to inadequate wastegate flow capacity, lean air/fuel ratio, poor compressor design, or excessive backpressure may not be fully alleviated.
- Increasing the boost pressure will also increase the intake air temperature. If the intake air pressure exceeds 220 degrees Fahrenheit (100 deg. Celsius), performance increases may be minimal and detonation may occur.
- For best performance and to safeguard against detonation, always use the highest octane gasoline available (91-octane minimum).
- Do not rely on the factory boost meter (if equipped) when adjusting the maximum boost pressure. Install an HKS auxiliary boost pressure meter to monitor manifold boost pressure levels.
- The utilization of an HKS A/F Knock Amp (air/fuel ratio meter) or an HKS exhaust gas temperature (EGT) meter is recommended to monitor engine (rich or lean) conditions.
- Mount the EVC control unit, display unit and harness away from high-power amplifiers, two-way radios, mobile phones, and their respective antenna cables to prevent malfunction of the EVC unit.

CONNECTION DIAGRAM

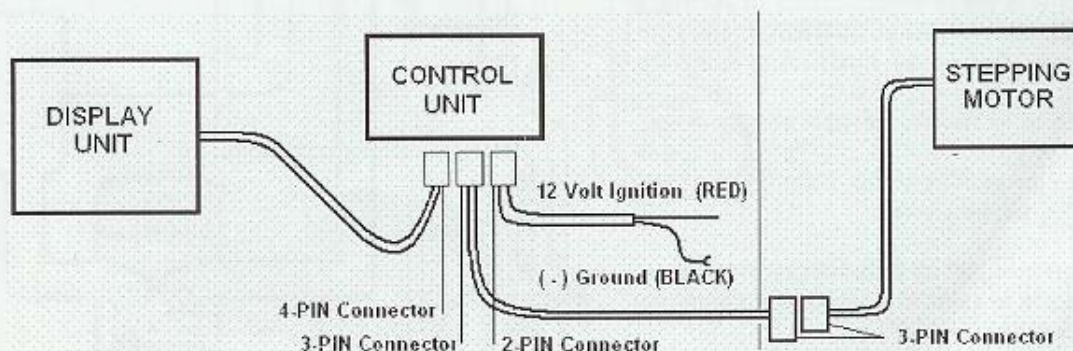

INSTALLATION

1. Disconnect the negative battery cable from the battery.
2. EVC stepping motor installation-
 - Determine an ideal mounting location for the stepping motor.
 - Mount the stepping motor to the chassis using the hardware provided with this kit.
 - Do not install the stepping motor close to the exhaust manifold or any area of high temperature.
 - Do not install the stepping motor where it will be exposed to water or moisture.
 - Ports 1 (B), 2 (I), and 3 (O) must face upward.
 - Lengths on all hoses must be kept as short as possible.

3. Vacuum Filter Installation-

- Install vacuum filters per diagram to the right. Make sure the filters are within 10cm (3.9") length from the stepping motor.
 - The 6mm vacuum filter should be installed with the short side facing the stepping motor.
 - Inspect the filters every 3000 miles. They must be clean for the EVC to function correctly. If the filter is contaminated or dirty, replace with a new (4mm) 4599-RA017 or (6mm) 4599-RA016. Do not attempt to clean the vacuum filter. If the filters frequently need replacement, relocating the pressure source may solve the problem.
4. Connect the red wire (2-pin harness) from the EVC to a 12-volt ignition source. Utilizing a voltmeter, find a wire that receives at least 12 volts with the key in the "IGNITION" position.
 5. Connect the black wire (2-pin harness) from the EVC to a chassis ground. Make sure there is no paint or rust on the ground surface. If there is, sand the surface until bare metal is exposed.

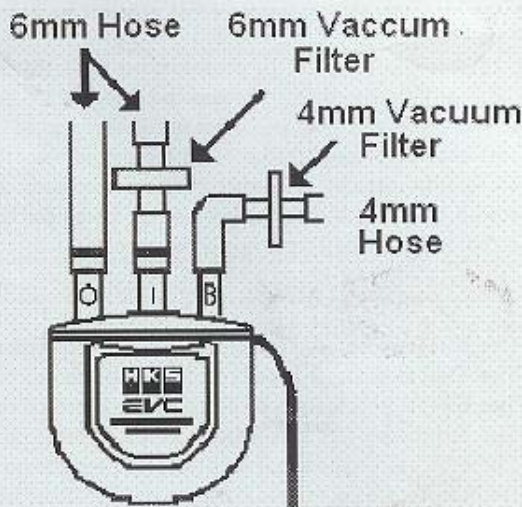

- **Determine if the vehicle is equipped with an internal wastegate (single port actuator), dual port actuator, or an external wastegate, then proceed to the corresponding installation instructions.**

INTERNAL WASTEGATE (SINGLE PORT ACTUATOR) INSTALLATION INSTRUCTIONS

Port #1 (B) - Connect to an uninterrupted intake manifold pressure source after the throttle body such as a compressor bypass signal line using the 4mm hose.

- Do not connect port #1 to the line that operates the fuel pressure regulator unless the supplemental instructions tell you to do so.
- This hose should be as short as possible and should not exceed 100cm (3'4").
- Install the 4mm vacuum filter within 10cm (3.9") of port #1 on the EVC stepping motor.

Port #2 (I) - Connect to a source of pressurized air such as a turbocharger compressor housing (discharge side) or compressor outlet pipe (before the intercooler) using the 6mm hose.

- This hose should be as short as possible and should not exceed 100cm (3'4").
- Install the 6mm vacuum filter within 10cm (3.9") of port #2 (In) on the EVC stepping motor.

Port #3 (O) - Connect to the port on the wastegate actuator.

- This hose should be as short as possible and should not exceed 100cm (3'4").

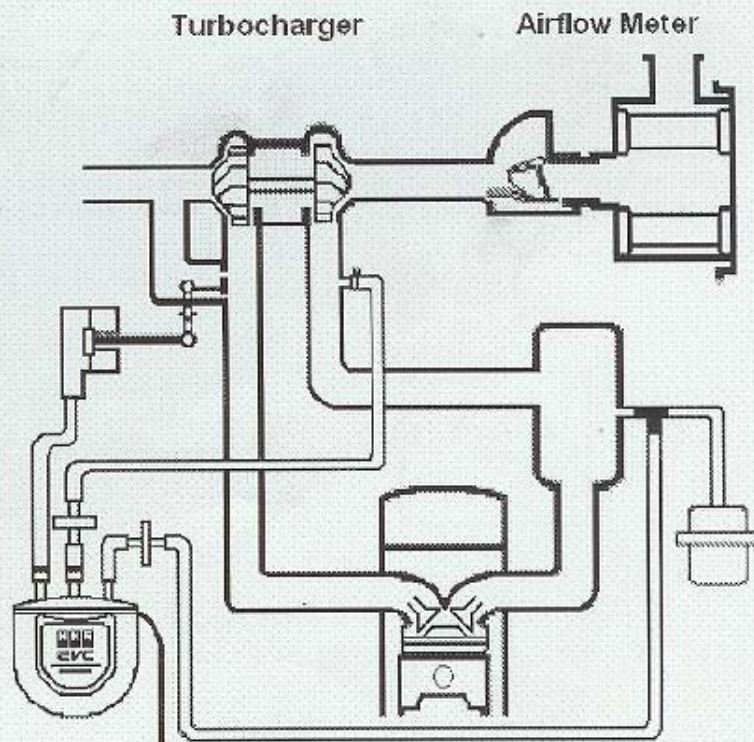

EXTERNAL WASTEGATE/DUAL PORT ACTUATOR INSTALLATION INSTRUCTIONS

Port #1 (B) - Connect to an uninterrupted intake manifold pressure source after the throttle body such as a compressor bypass signal line using the 4mm hose.

- Do not connect port #1 to the line that operates the fuel pressure regulator unless the supplemental instructions tell you to do so.
- This hose should be as short as possible and should not exceed 100cm (3'4").
- Install the 4mm vacuum filter within 10cm (3.9") of port #1 on the EVC stepping motor.

Port #2 (I) - Connect to a source of pressurized air such as the turbocharger compressor housing (discharge side) or compressor outlet pipe (before the intercooler) using the 6mm hose. Use the tee fitting supplied with this kit to connect a pressure line to the secondary port on the wastegate actuator.

- Both lines should be as short as possible and should not exceed 100cm (3'4").
- Install the 6mm vacuum filter within 10cm (3.9") of port #2 (In) on the EVC stepping motor.

Port #3 (O) - Connect to the port on the wastegate actuator.

- This hose should be as short as possible and should not exceed 100cm (3'4").

External Wastegate

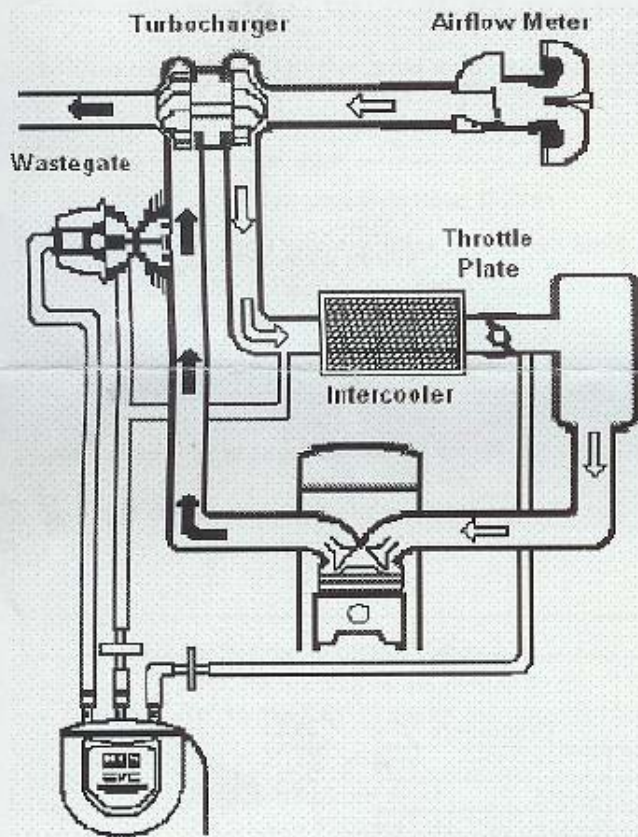

Dual Port Actuator

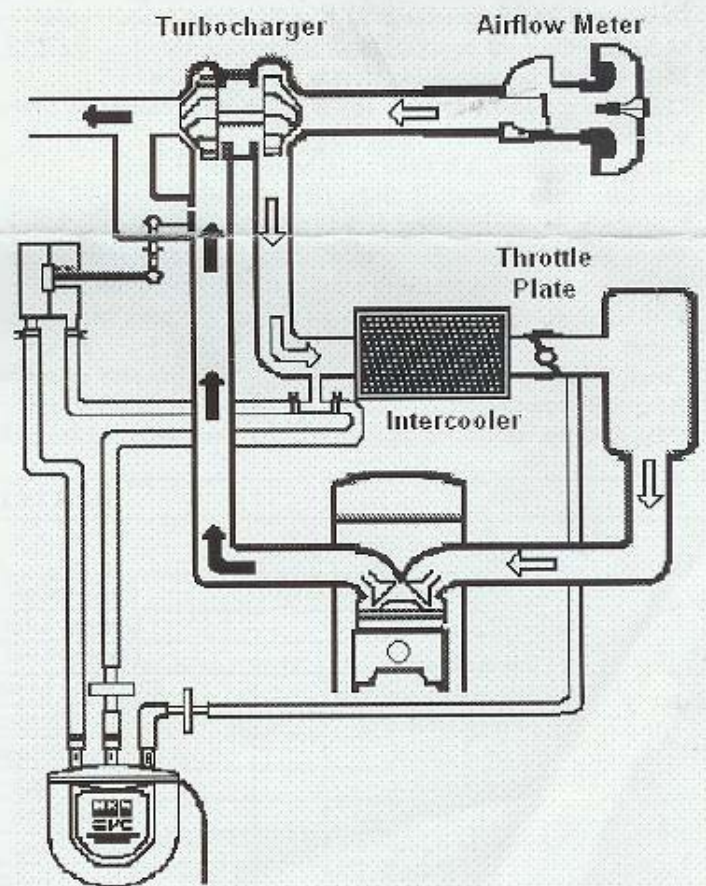

TROUBLESHOOTING

Notes

- If at any time the EVC does not adjust, the lock code number is forgotten, or the display reads an error code of "100" (no stepping motor memory) the display unit will have to be reset (see EVC Set-Up instructions, 7.2).
- If volume knob A or B was moved when the EVC power was off, the button(s) will flash until the knob is returned to its original position.
- If the ignition is shut-off before 10 seconds after the last setting was made, the last setting may not hold memory.

EVC Control Unit Will Not Illuminate:

- Power Connection- There must be a constant 12-volt power source under all conditions with the ignition "ON".
- Ground Connection- In some cases, paint, rust, or a loose bolt will cause a bad ground.
- Electronic Splice Connector- Visually from the outside, wire connections may look good. In some cases, the wires are not making contact inside the connector. Check the wires at both ends with a voltmeter to ensure continuity.

EVC Will Not Control Boost:

- Make sure the SW↔PO switch on the back of the unit is in the correct position.
- Check the hose connections to ports 2 (In) & 3 (Out) on the EVC stepping motor. EVC III, IV, and EZ stepping motors differ from EVC I, II and the new EVC stepping motors (see installation diagrams).
- Check for continuity at each wire on the 3-pin harness for a possible break in a wire. If an error code of "001" (communication error) is displayed, one of the wires has lost continuity.

Vehicle Is Not Building Enough Boost (Underboosting):

- Slowly turn up the underboosting A or B volume knob.
- Make sure the stock boost solenoid is disconnected.
- Make sure the boost warning level is not set too low.
- Check for possible improper set-up of the EVC display or control units. Read the manual again to verify that you are following the correct procedures.
- The vacuum filters (4 & 6mm) may be clogged or dirty.

Vehicle Is Building Too Much Boost (Overboosting):

- Turn down the overboosting A or B volume knob.
- Verify that there are no leaks in the hoses, and that all connections are tight. Check for hose damage such as pinholes or tears.
- Wastegate valve may be too small or actuator may be too weak.
- Turbocharger capacity may be too small (In this case, the boost curve will drop off during high rpm compared to the factory boost curve).
- Check for possible improper set-up of the EVC display or control units. Read the manual again to verify that you are following the correct procedures.
- Make sure the vacuum filters (4 & 6mm) are not damaged or cracked.

PARTS LIST

Quantity	Description	Comments
1	Display Unit	kPa
1	Control Unit	
1	Stepping Motor	
1	3-Pin Harness	L=2.7m (106")
1	2-Pin Harness	L=1.5m (59")
1	4mm Hose	L=1m (39")
1	6mm Hose	L=1m (39")
1	Tee Fitting	4x4x4mm
1	Vacuum Filter	4mm
1	Vacuum Filter	6mm
2	Spring Clamp	6mm
1	Double-Sided Tape	
5	Tie Wraps	L=100mm (4")
1	Stepping Motor Hardware Set	
1	Instruction Manuals	Install & Set-Up



ELECTRONIC VALVE CONTROLLER SET-UP INSTRUCTIONS PART # 45003-AK001 v.082102

Quick Manual

1. Ignition ON

Turn the key so the ignition is in the "ON" position. There is no need to start the engine.

2. Set the wastegate switch. SW or PO

Make sure the power on the EVC is off, if not, hold the (PWR) button down for more than 1sec to turn the unit off. Then set the bypass switch shown below to the correct setting.

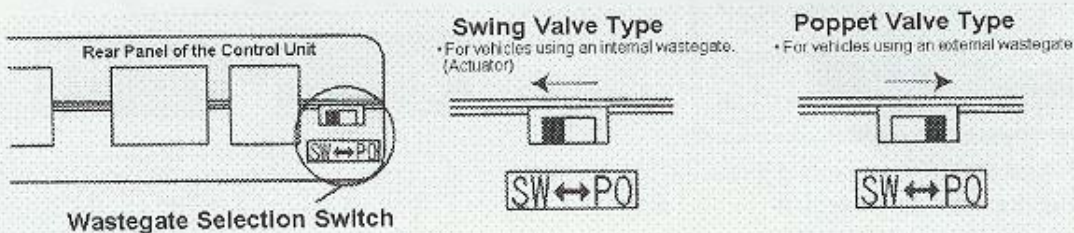

3. Turn the EVC power ON.

Hold down the power (PWR) button on either the display unit or control unit for more than 1sec. and turn the power of the EVC "ON".



OR

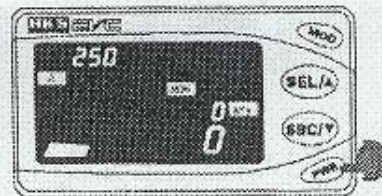

4. Setting the Warning Values.

First, the warning values need to be set.

To prevent turbo or engine damage caused by over-boosting, a warning value must be set.

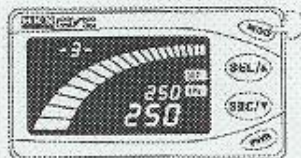
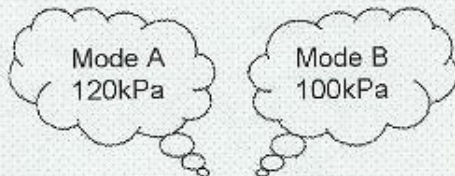

- (1) Decide on a target boost for mode A and mode B.

Example: Mode A 120kPa, and mode B 100kPa.

- (2) Press the (MOD) button 3 times to get into "Warning Value Setting Mode".

A "-3-" should display on the top left corner of the screen.

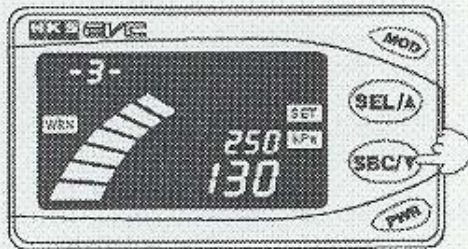

(3) Add 10kPa to the higher boost setting between mode A and mode B.

Example: 120kPa + 10kPa = 130kPa

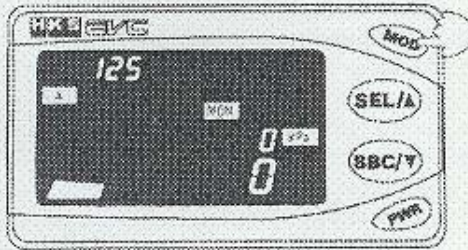

(4) Press the (MOD) button once to save and go back to the main mode.

5. Setting the boost for mode A/B

- For safety reasons, do not adjust the EVC while driving. Park the vehicle in a safe and designated area to make adjustments.



Red

(1) Make sure the _ on volume knob A is lit up red. If it's green, press the (PWR/SEL) button once (short press).



(2) Press volume knob A to pop the knob up. Then turn it all the way counter clockwise.



(3) Cross reference the digital display (large screen) and turn volume knob A slowly clockwise to add to the set value.



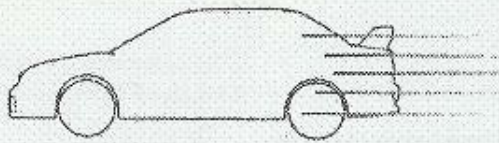

- (4) Try to use the highest gear possible (3rd or 4th gear) and apply load on the car on full open throttle.

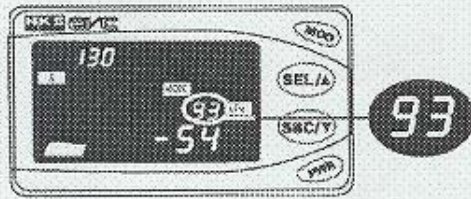

- (5) Verify the peak hold value.

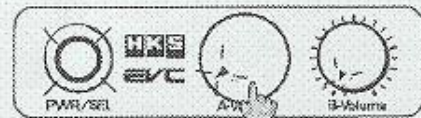

- (6) If the peak hold value is not close to your target boost, repeat steps (3) ~ (5) again.

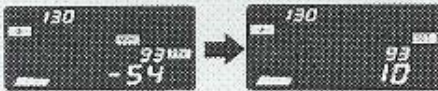

- (7) When the setting is done, push volume knob A back in.



- (8) Hold the (SEL/_) button for more than 1 sec. on the digital display unit to reset the peak hold value.

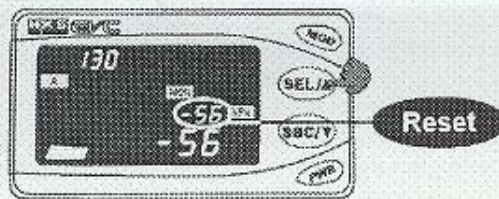

- (9) Press the (PWR/SEL) button once (short press) and verify that the _ on volume knob B is lit up red.



Red

- (10) Press volume knob B to pop the knob up. Then turn it all the way counter clockwise





(11) Repeat steps (3) ~ (5).

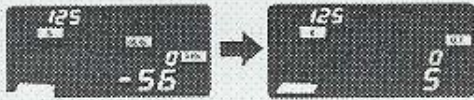

(12) Once the setting is over, push volume knob B back in.



(13) To select between mode A and mode B, press the (PWR/SEL) switch once (short press). The selected volume knob will light up red.
Example: The diagram shows when the mode A boost setting is selected.

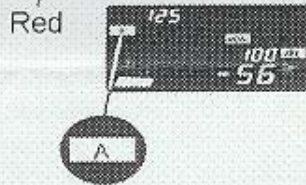

How to operate other functions

1. Monitor mode

1. 1. Boost control

Setting boost levels for both mode A and B must be done through the control unit.

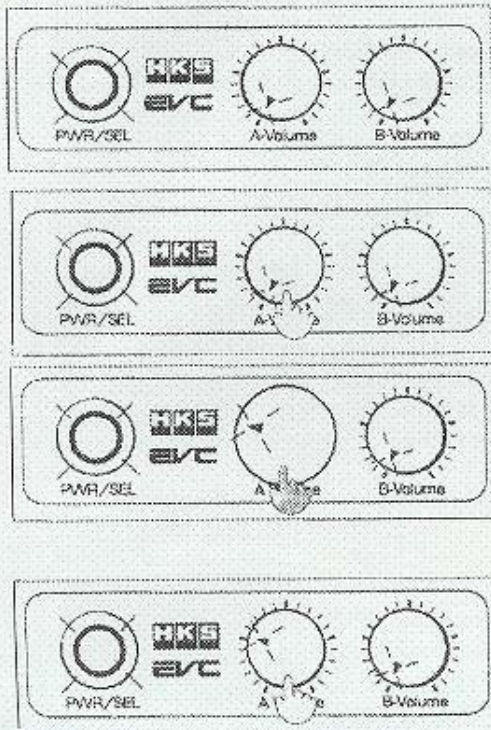

- (1) With the ignition ON, make sure the power button is ON.
 - The _ of the (PWR/SEL) button will light up red.
 - The _ of volume knob A or B will either be red or green. Red indicates the current selected knob. If it's green, press the (PWR/SEL) button once (short press) to switch over.
- (2) Once the A or B volume knob is selected, push out the knob to adjust the boost level.
- (3) Start full counter clockwise and slowly turn the knob to a desired boost level.
 - As a reference point, use the display's set value to add to the stock (baseline) boost level. For example: If the known baseline boost is 1.0 bar (100 kPa), by entering 50 kPa as the set value, the actual boost level should be near 1.5 bar.
 - The control unit increments are not a set value so cross-reference it with the digital display (large screen) to check the actual boost level.
- (4) When you are done, push the knob back in.

Notes

- If a setting is not performed within 4 seconds after the _ is lit up red, the display value (large) will return to monitor mode.
- Make sure the volume knob is pushed in whenever a setting is finished. If the knob is left popped up, there is a chance that the boost may change if accidentally hit.
- For vehicles equipped with sequential turbos, the primary turbo may not hit its maximum boost level until the secondary turbo kicks in.
- Boost lag may occur on vehicles equipped with actuators with soft (weak) springs.

1. 2. Peak Hold

When in monitor mode, the EVC will record and display its highest boost level reading. The memory of the peak/hold level will be updated automatically and can be reset manually.

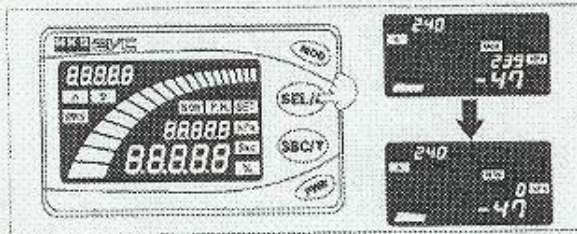

- (1) By holding down the (SEL/▲) button for more than 1 second, the peak/hold level will be reset.
 - The number on the digital display value will reset and will read "0".
 - When a new peak level is reached, the P.H. will flash and display a new peak reading.

1. 3. Scramble Mode

Hit the (SBC/_) button to activate the scramble mode.

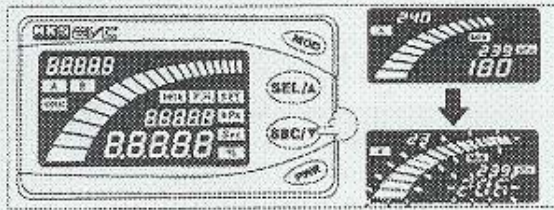

- (1) Press the (SBC/_) button.
 - When the scramble mode is activated, the (SBC/_) will turn red, the display will flash along with a quick set of audible beeps.

2. Scramble Setup Mode

This mode is used to set a value which adds to the set boost pressure when the scramble mode is activated.

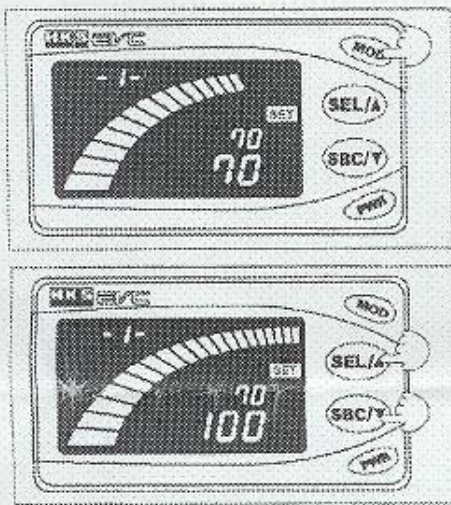

- (1) If the display unit is in monitor mode, press the (MOD) button once. If it is in any other mode, scroll through the modes until it displays a "-1-", which is the scramble setup mode.
 - The indicator will display "SET" on the screen.
- (2) Use the (SEL/_) or (SBC/_) button to input the values.
 - The digital display value (large) indicates the value currently being set. The digital display value (small) indicates the previous set value.
 - The setting value range is from 0~100 in increments of 1 kPa. This figure will be added on to the previously set boost level.

3. Scramble Time Setup Mode

This mode will set the time interval in which the scramble mode is active.

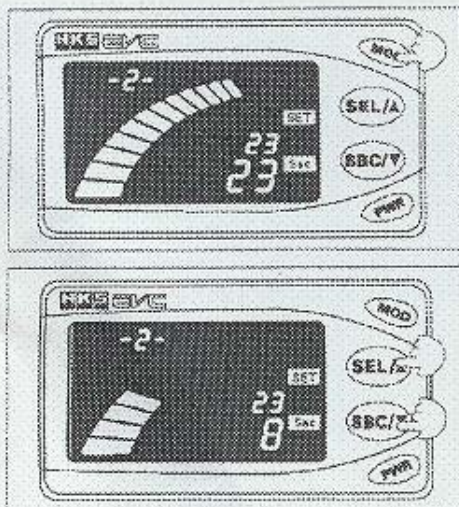

- (1) From the monitor mode, press the (MOD) button twice. If it is in any other mode, scroll through the modes until it displays a "-2-", which is the scramble time setup mode.
 - The indicator will display "SET" on the screen.
- (2) Use the (SEL/_) or (SBC/_) button to input the values.
 - The digital display value (large) indicates the seconds currently being set. The digital display (small) indicates the previous set time.
 - The setting value range is from 0~40sec. in increments of 1second.

Note

- When the (SBC/_) button is pressed, the scramble function will activate but will not start until the button is let go.

4. Warning Setup Mode

If the pressure in the surge tank exceeds the set boost warning level, it will trigger the warning function. When the warning is activated, the boost level will return to stock (baseline).

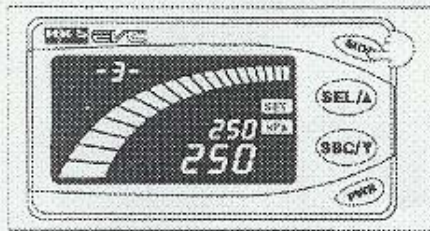

- (1) In monitor mode, press the (MOD) button 3 times. The top left corner should display a "-3-".
 - The indicator will display "SET" on the screen.

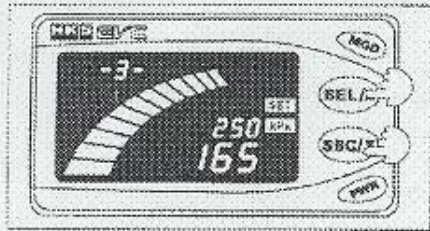

- (2) Use the (SEL/_) or (SBC/_) button to input the values.
 - The digital display value (large) indicates the value currently being set. The digital display value (small) indicates the previous set value.
 - The setting value range is from 0~250kPa in increments of 1kPa.
 - Initial setting is 250.

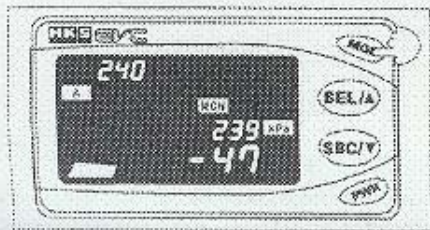

- (3) Press (MOD) button to return to the main screen.
 - Make sure to return to monitor mode or the new set values will not be recorded.
 - If the values are not recorded, the values will go back to default when the ignition or EVC power is turned OFF.

Notes

- As long as the boost level is set below the warning level, the warning will activate if the EVC see's 10kPa (for more than .5 seconds) over the set warning level.
- If for some reason the boost level is set above the warning level, the warning will activate when the EVC see's 5kPa (for more than .5 seconds) over the set warning level.
- When the warning is activated, the "WRN" on the display unit will light up, a series of audible beeps will be heard and the digital display value (small) will flash.
- When the surge tank pressure goes below 10kPa it will cancel the warning.

5. Display Setting Mode

This mode will determine the range of the bar graph.

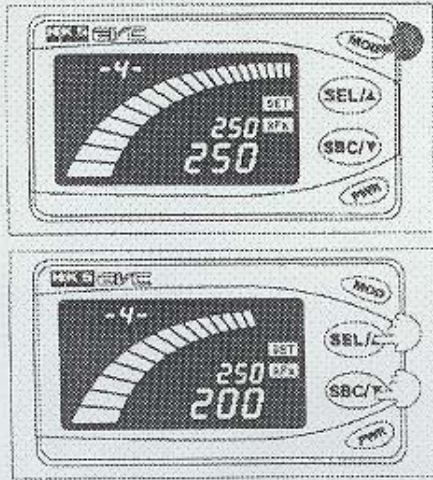

- (1) In monitor mode, hold the (MOD) button down for more than 1second. The top left corner should display a "-4-".
 - The indicator will display "SET" on the screen.
- (2) Use the (SEL/_) or (SBC/_) button to input the desired bar graph range.
 - The digital display value (large) indicates the value currently being set. The digital display value (small) indicates the previous set value.
 - The bar graph range is from 0~250kPa in increments of 5kPa.
 - Initial setting is 250.

Note

- If the bar graph is set to the same value as the warning boost level, the bar graph can be used to quickly glance at the display to see the real time boost level in relation to the warning level. The bar graph is much easier to see than the digital display value.

6. Backlight Brightness Adjustment Mode

This mode will adjust the brightness of the digital display.

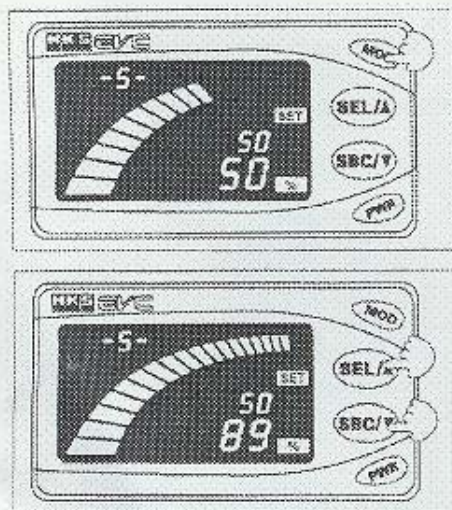

- (1) In monitor mode, hold the (MOD) button down for more than 1second and press (MOD) 1 more time. The top left corner should display a "-5-".
- (2) Use the (SEL/_) or (SBC/_) button to input the values.
 - The digital display value (large) indicates the value currently being set. The digital display value (small) indicates the previous set value.
 - The brightness setting range is from 0~100% in increments of 1%
 - As the values decrease, the display will get darker.
 - Initial setting is 100%.

7. Lock Code Setting Mode

To lock in valuable settings/data use the lock code setting.

7.1. Setting the Lock Code

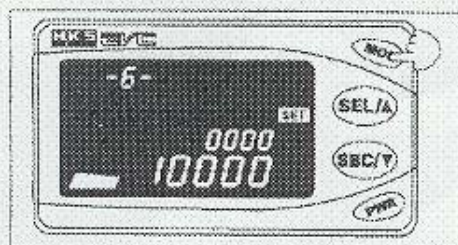

- (1) In monitor mode, hold the (MOD) button down for more than 1second and press (MOD) 2 times. The top left corner should display a "-6-".

- The digital display value (small) will display as follows.

- "0000" : Lock code not set
- "----" : Lock code set

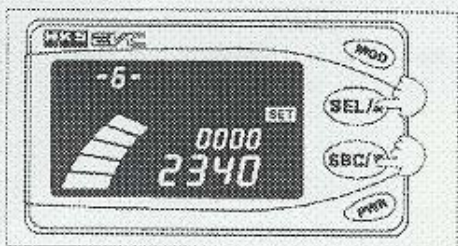

- (2) Use the (SEL/_) or (SBC/_) button to input a lock code number.

- The digital display value (large) indicates the code number currently being set. The digital display value (small) indicates the previously set code number.
- The setting value range is from 0-10000 in increments of 1.
- Initial setting is 10000.

- (3) Press (MOD) once to activate the lock code and return to monitor mode.

- The (MOD) button will light up red when the lock code is activated.

Note

- When the lock code is set, the EVC (display & control unit) power ON/OFF, changing the boost setting mode (A/B), re-setting the peak hold level, and scramble are still active. For any other changes, the lock code must be released (see 7.2 Lock Code Release).

7.2. Lock Code Release

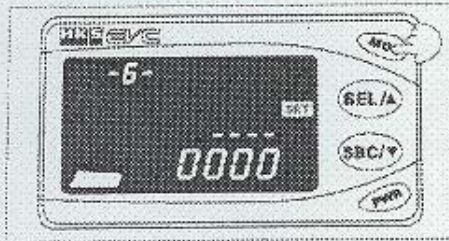

- (1) In monitor mode, hold the (MOD) button down for more than 1 second and press (MOD) 2 times. The top left corner should display a "-6-".
 - The digital display value (small) will show a "----".

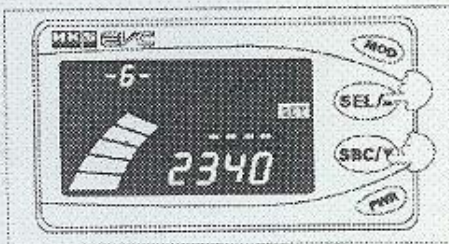

- (4) Use the (SEL/_) or (SBC/_) button to input the lock code number.

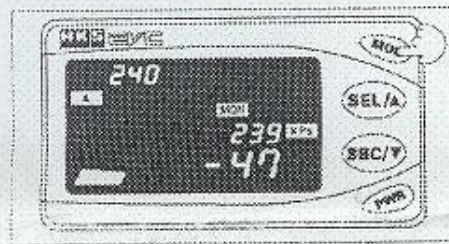

- (5) Press (MOD) once to release the lock code and return to monitor mode.
 - If the number inputted in step (2) matches the previously set lock code number, it will release the lock. If the number does not match, it will not release the lock and you will have to try again.
 - The (MOD) button will light up green when the lock code is released.

Note

- If the lock code number is forgotten, a data reset (see below) must be done. When the data is reset, all stored memory will be lost. The only time the EVC should be reset is if the lock code is forgotten.

Data Reset



- (1) Hold down the (PWR/SEL) button until the EVC power shuts OFF.
 - The _ of the (PWR/SEL) switch will light up green, with both lights on the _ of A/B volume knobs turned off.

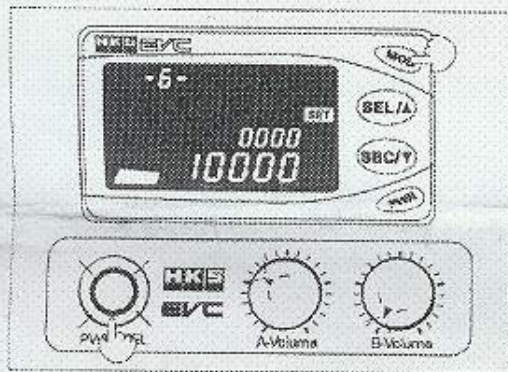
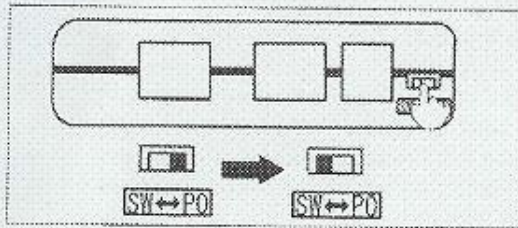
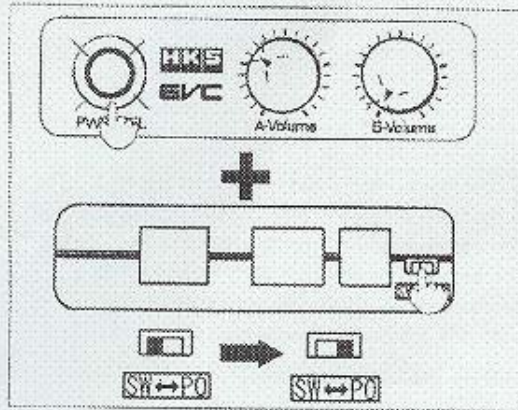

- (2) While holding down the (PWR/SEL) button on the control unit, flip the bypass switch (SW/PO) on the back of the unit.
 - The diagram shows an example when the bypass switch is set on swing valve (SW). If the unit is set on poppet valve (PO), the bypass switch will be reversed.
 - The vehicles ignition (12V) must remain on.

- (3) Flip the bypass switch back to the original position.
 - The (PWR/SEL) button does not have to be held down during this step.
 - The diagram shows an example when the bypass switch is set on swing valve (SW). If the unit is set on poppet valve (PO), the bypass switch will be reversed.

- (4) You should hear a long audible beep. When the beep stops, turn the ignition (12V) off and then back on.

- (5) Turn the power ON by holding down the (PWR/SEL) button down for more than 1 second.
 - The (PWR/SEL) button will light up red.
 - The Lock Code should be back to default.
 - If the (PWR/SEL) button is flashing, make sure the bypass switch is back in the correct position.